

MOUNTING INSTRUCTIONS: 1150 SERIES SURFACE MOUNTED 1500 LB. ELECTROMAGNETIC LOCK

Model Numbers:

1150, 1152 & 1155

READ THOROUGHLY BEFORE INSTALLING

Handle Electromagnets and Armatures carefully. Any damage to the mating surfaces may significantly reduce holding efficiency.

The 1150 Series Electromagnet assembly mounts firmly and rigidly to the underside of the header on the stop side of the door. The armature mounts to the face of the door with special hardware for proper floating action to assure total mating with the face of the Electromagnet.

Note: For Inswing door mounting the TJ series is required. Armature hardware provided for 1-3/4" thick Doors. Contact factory for other mounting applications

Note from applicable template that 2-7/8" minimum reveal is required to assure rigid mounting of the Electromagnet assembly. If this minimum is not met see Fig. 1 to determine the need for either an 1180 Series Filler Plate or an 1190 Series Angle Bracket. Consult Application Bulletin "Elevation Profiles" for specific part numbers.

Mark door(s) and frame for drilling in accordance with applicable template dimensions. The 1150 Series is for single outswinging doors, and the 1152 Series and 1155 Series are for pairs of outswinging doors without center mullion. All measurements are to be made with door(s) in closed position.

Follow this 4 step mounting process:

STEP 1) FRAME PREPARATION:

Remove housing cover prior to lock installation. Prepare frame for Electromagnetic lock assembly by drilling for #14 Sheet metal screws or for drilling and tapping for 1/4-20 machine screws both with external tooth lock washers. Tighten screws just enough to hold the unit in place. If filler plate is used, drill clearance holes in filler plate for Electromagnet mounting screws. CAUTION: Do not attach mounting plate to filler plate only. Mounting plate should be attached through filler plate. Drill clearance hole through filler plate for wiring. Make all electrical connections in accordance with applicable wiring diagrams, using either wire nuts or crimp connectors.

FULL WIDTH STOP
WITH SURFACE MOUNT
ARMATURE

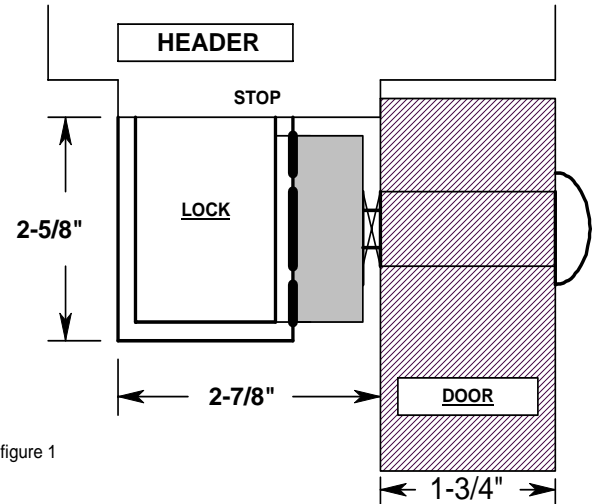

figure 1

STEP 2) ARMATURE PREPARATION: *fig.3 over*

Prepare armature for mounting: Note that armature has two 3/16th dia. holes open from back only. Press the two roll pins provided into these holes. Tap pins gently until they are firmly seated being extremely careful not to mar the face of the armature.

Insert one spring washer on the 5/16-18 shoulder screw then insert the screw through the armature. Add three spring washers and the flat washer. (per diagram enclosed in mounting kit)

STEP 3) ARMATURE MOUNTING: THRU BOLT MOUNTING HOLLOW METAL DOOR *fig.2A*

Drill 11/32 hole through door enlarge hole in outside face to 1/2" for knurled sex nut. BE SURE ROLL PINS POCKET and float freely in 1/4" holes in door. If not, remove armature and enlarge holes in door. Insert shoulder screw armature assembly thru face of door, being sure that spring washers remain over shoulder, and hold firmly against door by pushing directly on head of screw. Insert sex nut from opposite face and assemble. When armature is floating freely, Tighten 5/16-18 shoulder screw securely with allen wrench.

OVER.

CONTINUED.

THRU BOLT MOUNTING IN SOLID WOOD DOOR

fig.2B

Drill 1/2" hole through door; insert shoulder screw/armature assembly thru face of door, being sure that spring washers remain over shoulder. Hold firmly against door by pushing directly on head of screw. Insert sex nut from opposite face and assemble.

MACHINE SCREW MOUNTING *fig.2c*

Door must be properly reinforced to 3/8" minimum thickness and structured for 1500 lb load. Drill and tap thru reinforcing for 5/16-18 machine screw. Insert shoulder screw/armature assembly, being sure that spring washers remain over shoulder and flat washer is between shoulder and face of door.

4) LOCK & ARMATURE ALIGNMENT

With the DOOR IN THE CLOSED POSITION AND THE ELECTROMAGNET ENERGIZED make sure the armature is fully engaged and aligned. Next position the mounting plate

so that the door is snug against stops then tighten the #14 Sheet metal screws or the 1/4-20 machine screws at each end of the unit.

TURN POWER OFF: Using the two mounting holes; (three for double unit 1152) behind the Electromagnet as a physical template, drill for # 10 Sheet metal screws or drill & tap for 10-32 machine screws. After securing the unit with these back screws and lock washers provided; check installation alignment of Armature and Electromagnet by opening & closing the door while turning the system on and off. Armature surface must be in full contact with top and bottom rails of the Electromagnet as shown in Fig. 1 .

When all checks out satisfactory, replace housing cover.

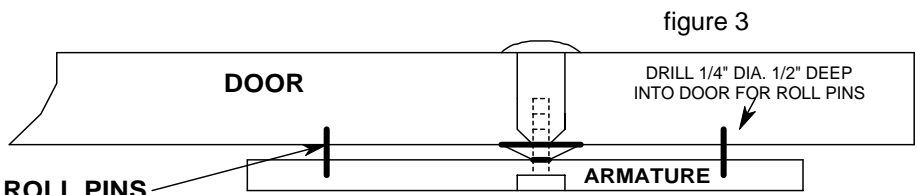
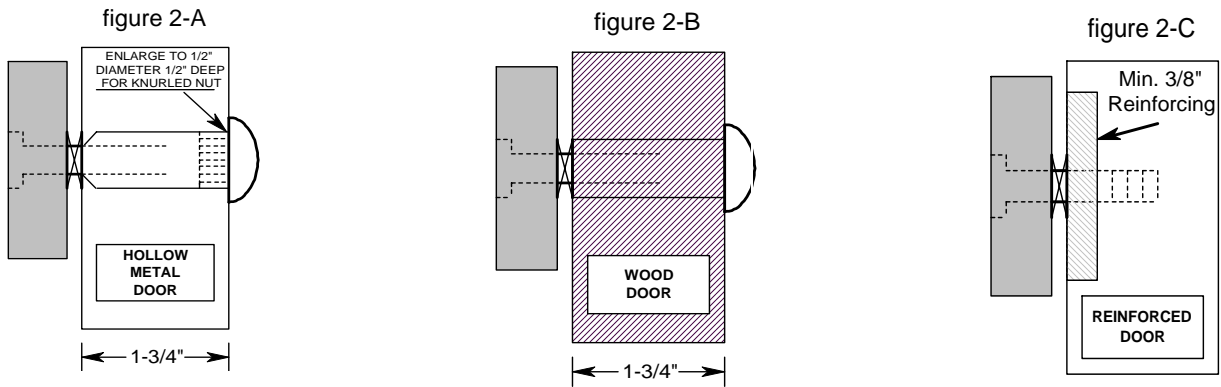

DRIVE 2 ROLL PINS INTO HOLES PROVIDED IN ARMATURE. MAKE SURE PINS BOTTOM

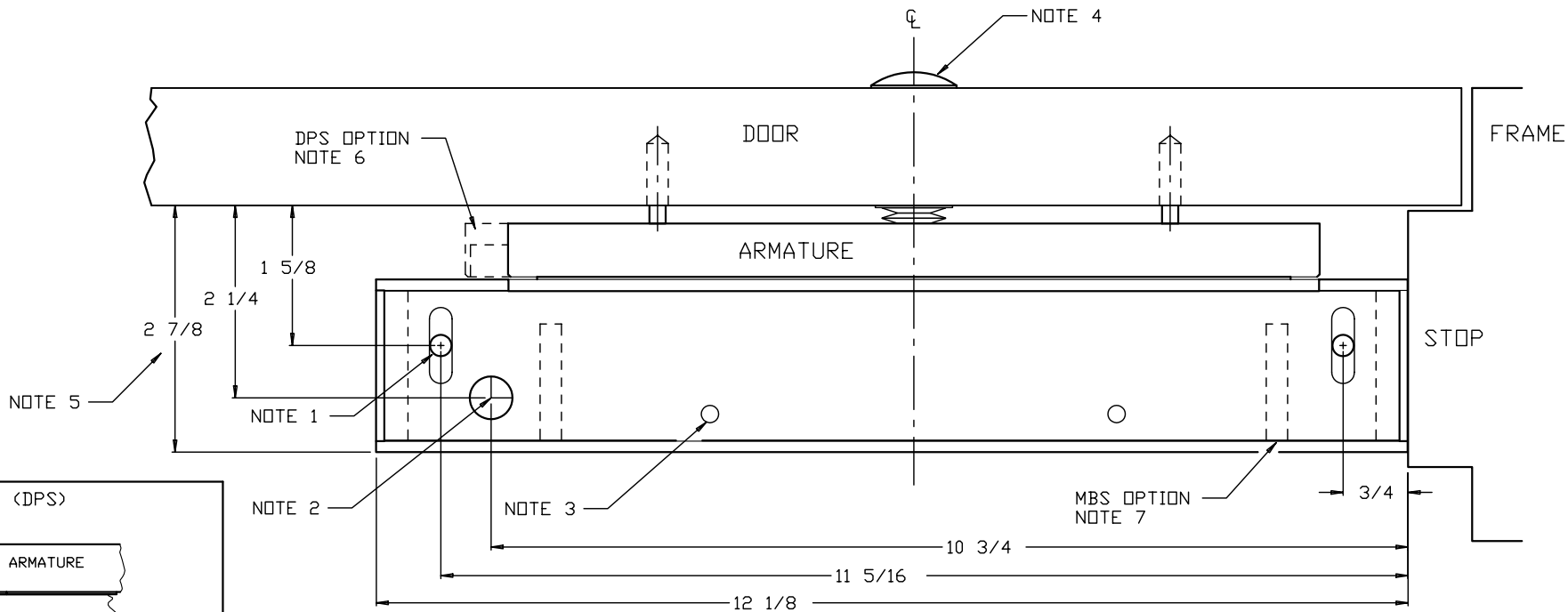

OPTIONS:

DOOR POSITION SWITCH (DPS)

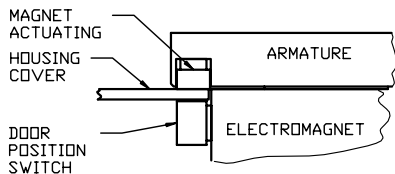

MAY BE AT EITHER END OF ELECTROMAGNET, AND ON EITHER LOCK JAMB OR HINGE JAMB END.

WIRE COLOR	FUNCTION	MODE STATUS WITH DOOR CLOSED & SW ACTUATED
BLACK	COMMON	
WHITE	N.D.	HELD CLOSED
RED	N.C.	HELD OPEN

SPEC: SPDT, .1 AMP @ 38 VOLTS

CONCEALED MAGNETIC BOND SWITCH (MBS)

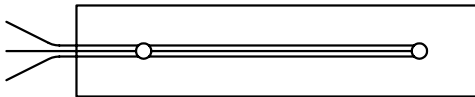

WIRE COLOR	FUNCTION	MODE STATUS WITH DOOR CLOSED & SW ACTUATED
GREEN	COMMON	
WHITE	N.D.	HELD CLOSED
RED	N.C.	HELD OPEN

SPEC: SPDT, .1 AMP @ 24 VOLTS

LED INDICATOR LIGHTS

LED COLOR CHOICE:

R - RED
G - GREEN

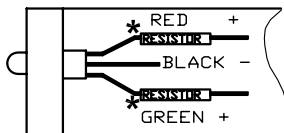

* LED IS SET FOR 24VDC OPERATION. FOR 12VDC INPUT CUT OFF RESISTOR

INPUTS:
12 TO 28 VOLTS DC
.03 AMPS @ 24VDC

BEFORE INSTALLING, READ ALL MOUNTING INSTRUCTIONS THOROUGHLY!

NOTES:

1. DRILL & TAP FRAME FOR 1/4"-20 MACHINE SCREW, OR #14 SHEET METAL SCREW. SLOT PERMITS SOME FLEXIBILITY IN HOLE LOCATION, AND HOLE CAN BE CENTERED UP TO 1 15/16" FROM FACE OF DOOR IF NECESSARY FOR THE FIRMEST MOUNTING LOCATION.
2. WIRE ACCESS HOLE IN THE MOUNTING PLATE IS 1/2" DIA. DRILL 9/16" DIA. HOLE IN FRAME AS SHOWN, BREAK EDGES OF HOLE AND CLEAN.
3. ONLY AFTER LOCK HAS BEEN PROPERLY POSITIONED, USE THE REMAINING HOLES AS A FIXED TEMPLATE TO DRILL & TAP FOR #10-32 MACHINE SCREWS OR #10 SHEET METAL SCREWS IN THE HOLE CENTERS.
4. SEE DETAILED MOUNTING INSTRUCTIONS FOR APPLICABLE DOOR PREPARATION FOR MOUNTING ARMATURE.
5. SEE 1150 SERIES ELEVATION PROFILES (IN 3 RING BINDER) TO DETERMINE NEED FOR AND SELECTION OF 1150 SERIES FILLER PLATE OR 1150 SERIES SOFFIT ANGLE BRACKET.
6. DPS (SEMI CONCEALED DOOR POSITION SWITCH), IF APPLICABLE.
7. MBS CONCEALED MAGNETIC BOND SENSOR, IF APPLICABLE.

TITLE 1150 SERIES SURFACE APPLICATION ON SINGLE OUTSWINGING DOOR INSTALLATION: LOCK PREPARATION					
DRAWN	GSG	DATE	4/10/02	SCALE	TO FIT
APPR.	JTF	DATE	11/16/05	UNITS	INCHES
CAD FILE			1150 MOUNT_1.DWG	DWG. NO.	
SHEET			1 OF 2	SIZE	A



DWG. NO.	T115002-1	REV.	A
----------	-----------	------	---

BEFORE INSTALLING, READ MOUNTING INSTRUCTIONS THOROUGHLY!

SEE MOUNTING INSTRUCTIONS FOR DRILLING AND TAPPING FOR MACHINE SCREW OR THROUGH BOLT MOUNTING

DRILL 1/4" DIA X MIN 3/4" DEEP, 2 PLACES IN DOOR FOR ARMATURE PINS

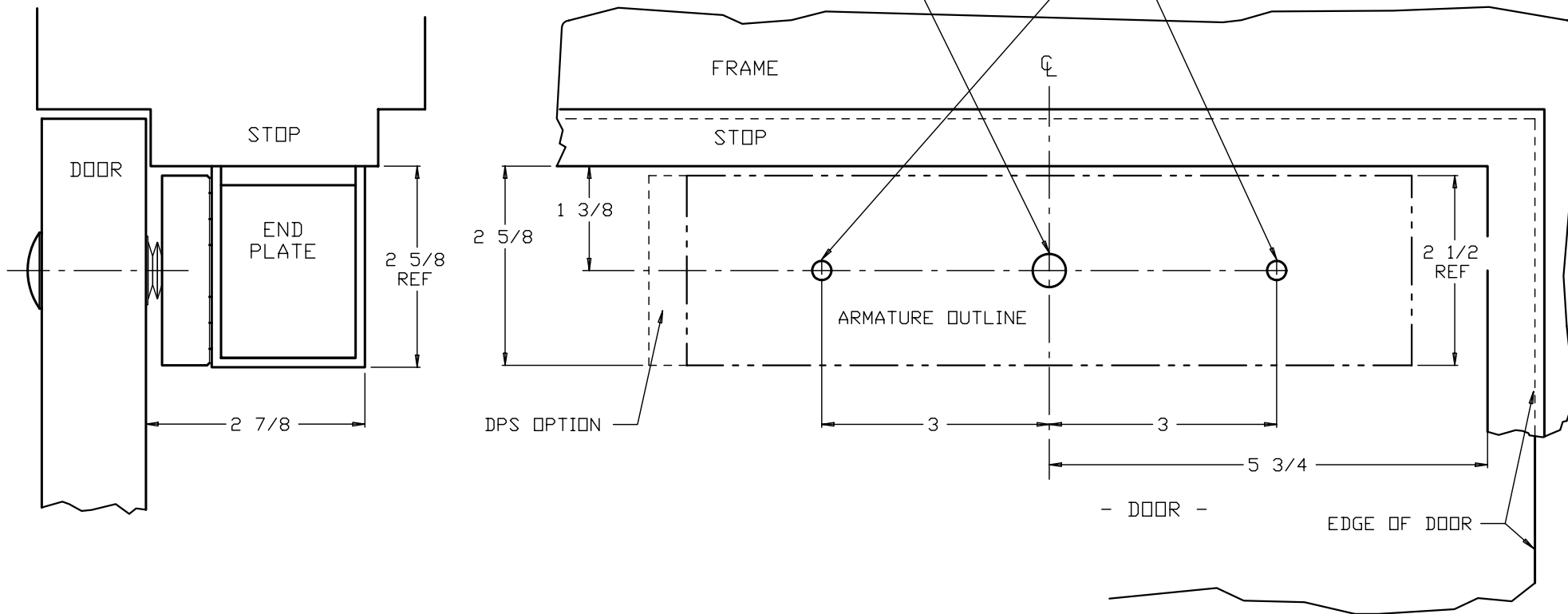

NOTE:

1. REINFORCING AND STRUCTURING IS REQUIRED TO WITHSTAND 1500 LB LOAD.

TITLE 1150 SERIES SURFACE APPLICATION ON SINGLE OUTSWINGING DOOR: ARMATURE DOOR PREPARATION

 **DORTRONICS**
SYSTEMS, INC.

(NC)	(NC)	(NC)	DRAWN	GSG	DATE	4/10/02	SCALE	TO FIT	CAD FILE	1150 MOUNT_2.DWG	DWG. NO.	T115002-2	REV.	NC
REV.		REVISION DESCRIPTION	DATE	APPR.	XXX	DATE	XX/XX/XX	UNITS	INCHES	SHEET 2 OF 2	SIZE	A		

1150 SERIES DUAL VOLTAGE MAGNET: WIRING DETAIL / CURRENT DRAW

VERIFY MODEL BELOW

1150 / 1155

SPECS:
300 mA MAX @ 24VDC
600 mA MAX @ 12VDC

1152

SPECS:
600 mA MAX @ 24VDC
1200 mA MAX @ 12VDC

24 VOLT CONNECTION (FROM FACTORY)

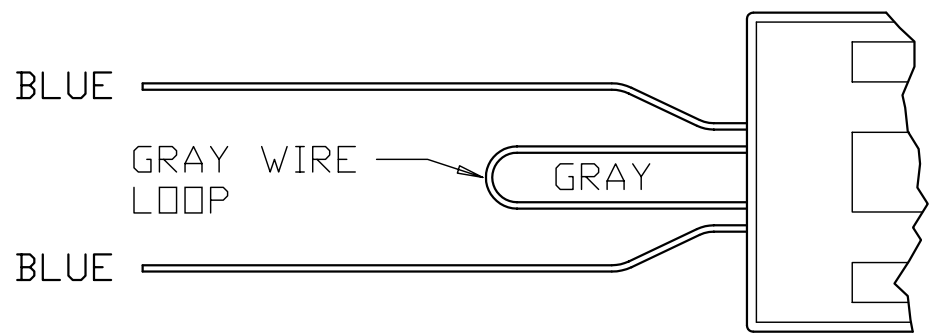

12 VOLT CONNECTION (FIELD MODIFIED)

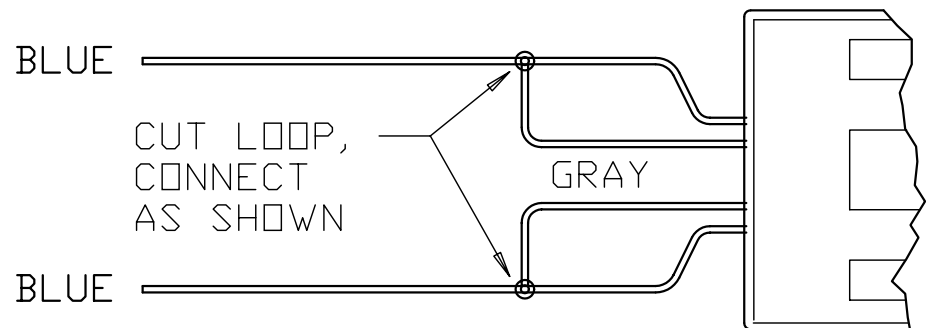

			TOLERANCES, (NON-ACCUM): (UNLESS SPECIFIED) .XXXXX : +/- .0025 .XXXX : +/- .005 .XXX : +/- .010 .XX : +/- .015 FRACT : +/- 1/64 ANGLES : +/- 1/2 DEGREE		TITLE 1150 SERIES DUAL VOLTAGE				
			MATERIAL XXX		CAD FILE 1150 DUAL				
			FINISH XXX		SHEET 1 OF 1		SIZE A		
			DRAWN XXX		DATE XXX		SCALE TO FIT		
			APPR. XXX		DATE XX/XX/XX		UNITS INCHES		
					DWG. NO.		REV.		
					1150 DUAL		NC		
REV	REVISION DESCRIPTION	DATE							

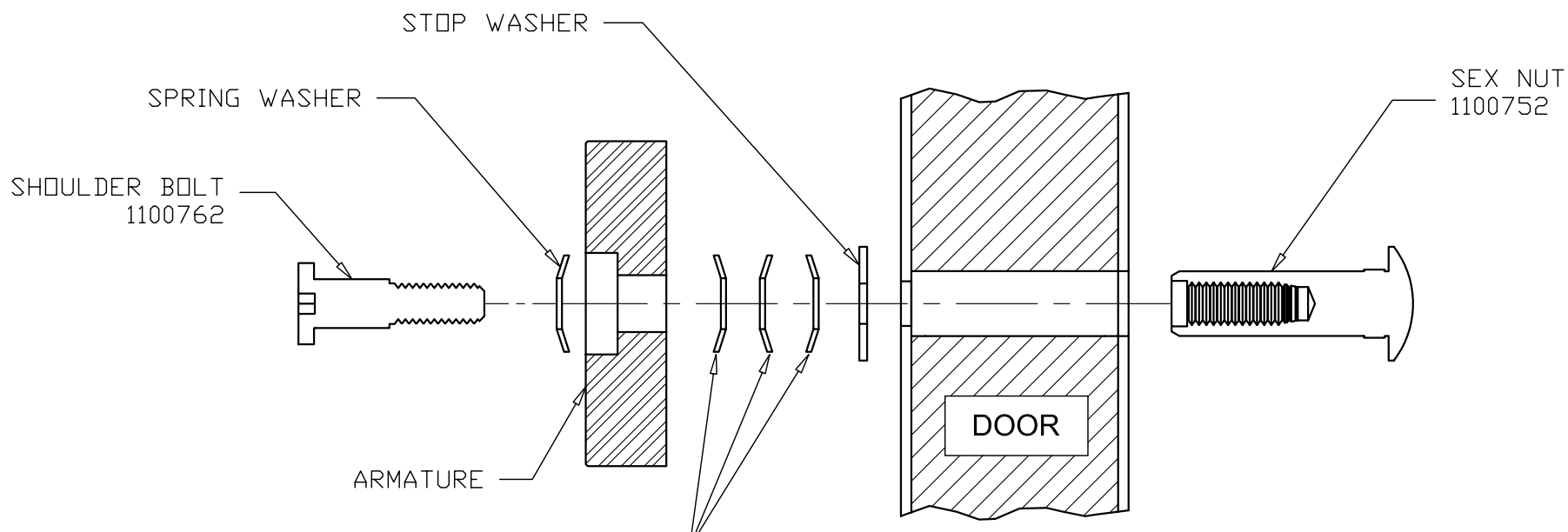

**DORTRONICS
SYSTEMS, INC.**

1668 SAG HARBOR TPKE., SAG HARBOR, NY 11963
TEL: (631) 725 0505 FAX: (631) 725 8148 TOLL FREE: 800 906 0137
WEBSITE: DORTRONICS.COM EMAIL: SALES@DORTRONICS.COM

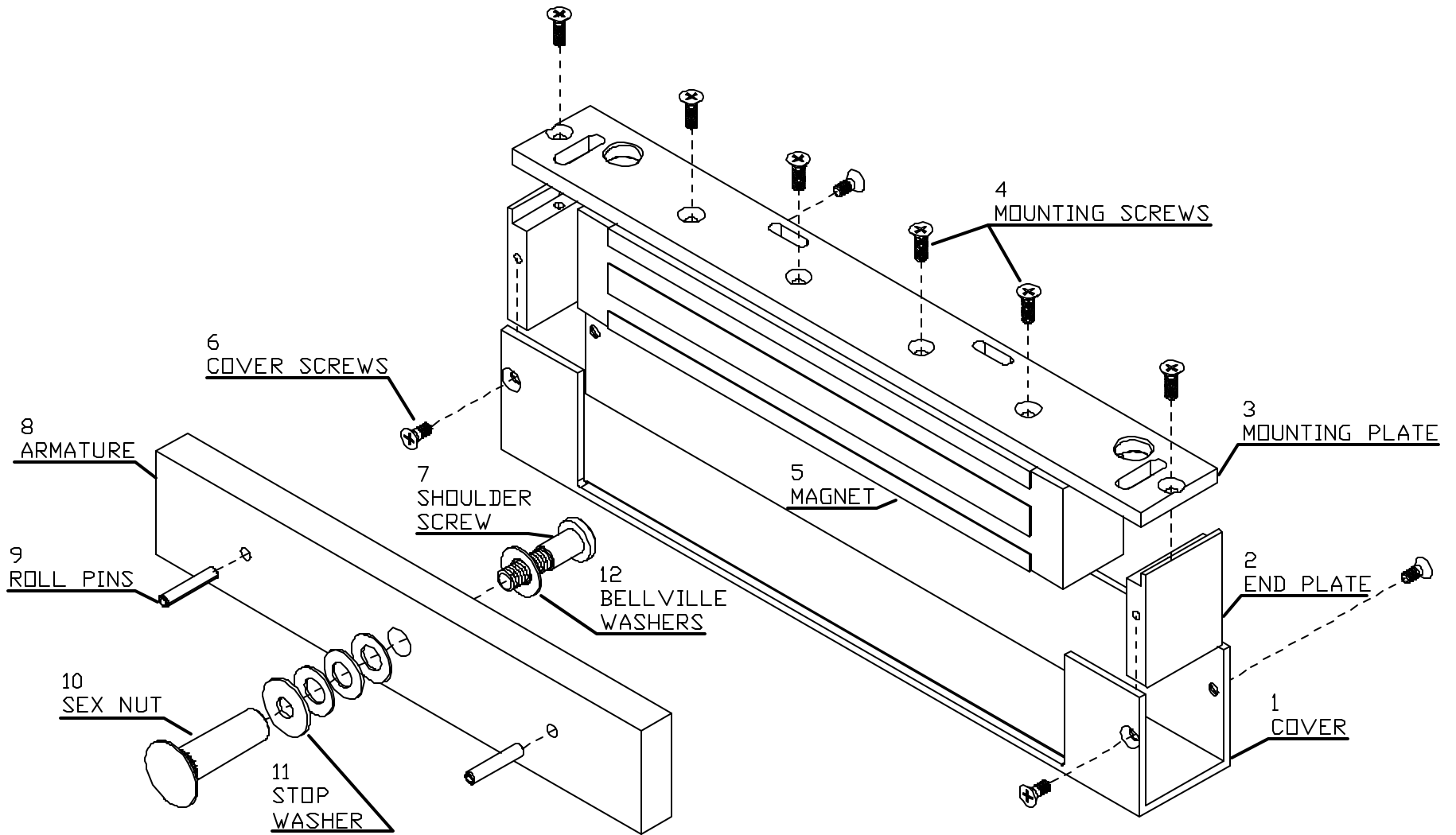

1150 SERIES ELEVATION PROFILES

AB1180_91_2_3_4_1150_P1

TYPICAL OUTSWINGING DOOR APPLICATIONS

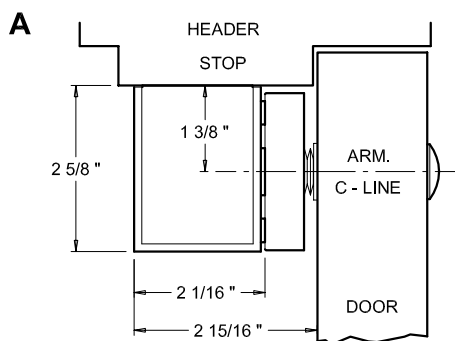

ON FULL WIDTH STOP WITH SURFACE MOUNTED ARMATURE

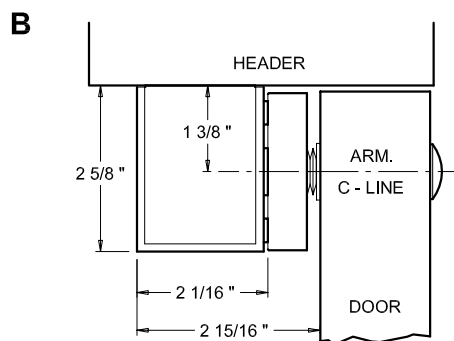

IN CASED OPENING WITH SURFACE MOUNTED ARMATURE

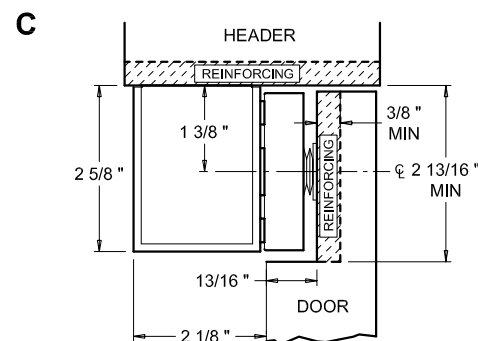

IN CASED OPENING WITH POCKETED ARMATURE

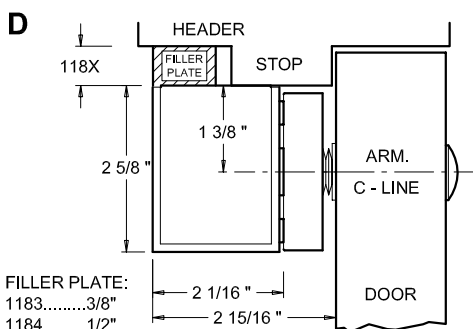

FILLER PLATE:
1183.....3/8"
1184.....1/2"
1185.....5/8"

1180 SERIES FILLER PLATE FOR FRAME WITH NARROW STOP

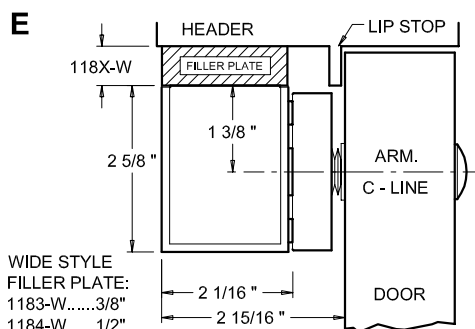

WIDE STYLE FILLER PLATE:
1183-W.....3/8"
1184-W.....1/2"
1185-W.....5/8"

1180-W SERIES WIDE FILLER PLATE FOR FRAME WITH LIP STOP

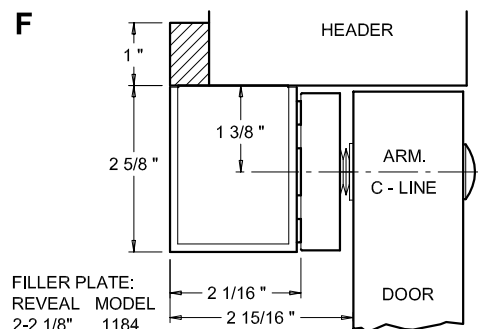

FILLER PLATE:
REVEAL MODEL
2-2 1/8".....1184
1 7/8-2".....1185

1180 SERIES FILLER PLATE AS HEADER EXTENSION BLOCK

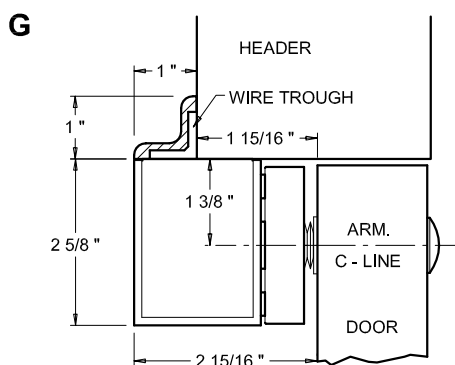

1191 ANGLE BRACKET

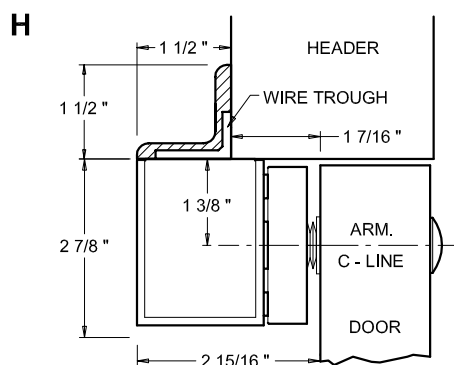

1192 ANGLE BRACKET

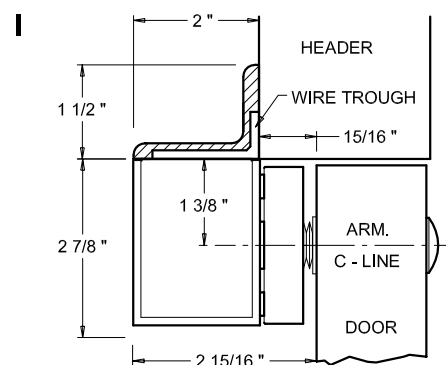

1193 ANGLE BRACKET

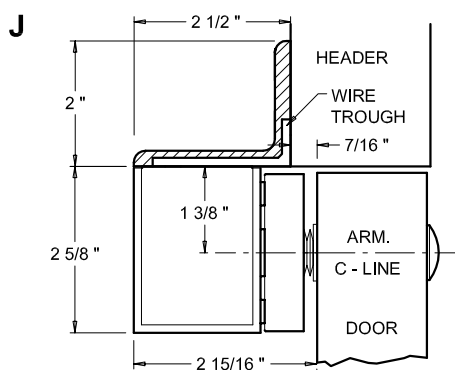

1194 ANGLE BRACKET



**DORTRONICS
SYSTEMS, INC.**

1668 SAG HARBOR TPKE., SAG HARBOR, NY 11963
TEL: (631) 725 0505 FAX: (631) 725 8148 TOLL FREE: 800 906 0137
WEBSITE: DORTRONICS.COM EMAIL: SALES@DORTRONICS.COM

1150 SERIES ELEVATION PROFILES

AB1195_6_7_1150_P2

TYPICAL INSWINGING DOOR APPLICATIONS

A

REFER TO THE APPLICATION BULLETIN FOR 1176 SERIES SPACERS

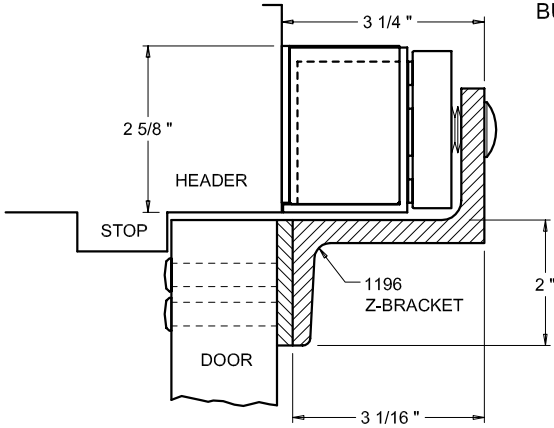

TOP JAMB MOUNT WITH STANDARD INSWINGING DOOR

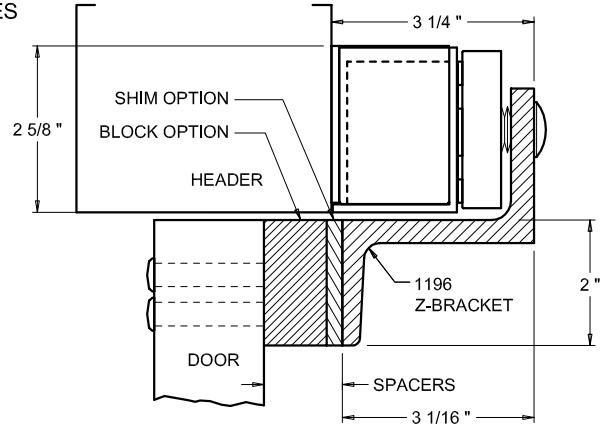

TOP JAMB MOUNT ON CENTER HUNG INSWINGING DOOR

TYPICAL SINGLE & BI-PART SLIDING DOOR APPLICATIONS

B

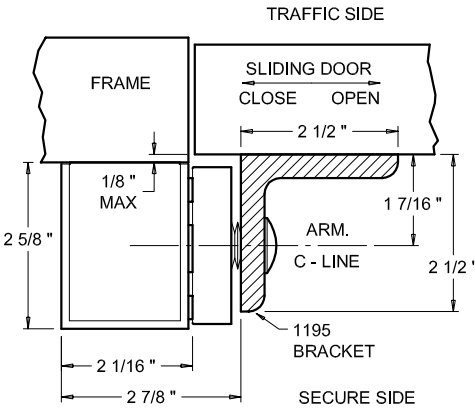

1195 ARMATURE BRACKET ON SINGLE SLIDER

C

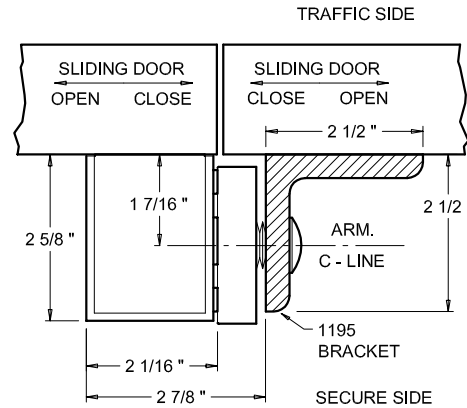

1195 ARMATURE BRACKET ON BI-PART SLIDERS

D

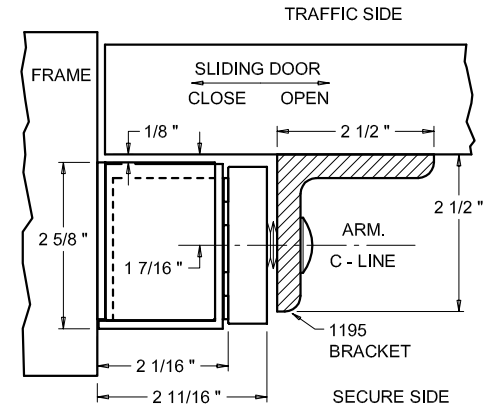

BACK MOUNT LOCK AND 1195 ARMATURE BRACKET ON SINGLE SLIDER

E

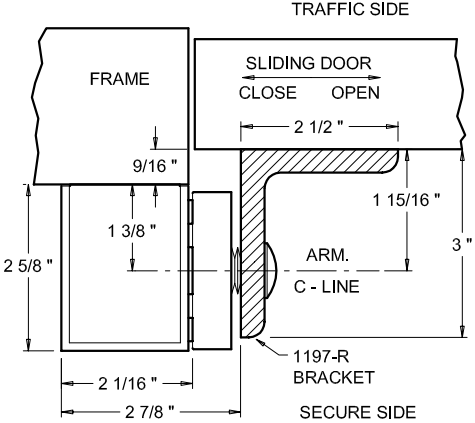

1197-R ARMATURE BRACKET ON SINGLE SLIDER

F

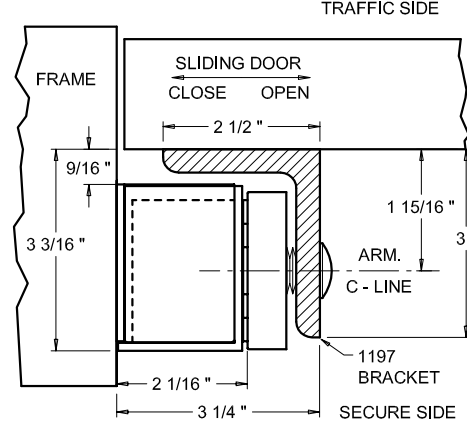

BACK MOUNT LOCK AND 1197 ARMATURE BRACKET ON SINGLE SLIDER

