



# 48500 Series USER CONFIGURED INTERLOCK CONTROLLER

The 48500 series PLC interlock controller is a cost-effective method for operating door interlock and mantrap systems with up to five doors. The fully integrated controller is a one-board solution that gives the user complete control over the control logic. Doors may be normally locked or unlocked, fail safe or fail secure. They may be selectively interlocked or operated independently of the other doors. Lock relays can be set for either powered or unpowered (dry) contacts.

Switches and jumpers are used to configure the controller for the specific application required. No programming skills are needed. There are three adjustable on-board timing functions. One timer energizes the door alarm relay if a door is propped open. A second timer controls the unlock time when enabled. A third timer controls the time that doors remain unlocked during an emergency egress.

The complete system includes a 4 Amp 12 - 24 Volt DC power supply with a supervised Fire Alarm Interface in a lockable metal enclosure. The Fire Alarm Interface will shut down power at the terminals when the fire alarm input is either shorted or open (such as the activation of a pull box). The fire alarm DIP switch must be set to “enable”,

**IMPORTANT:** The supervised fire alarm interface cannot be connected in series or parallel with other power supplies. Each supply requires a separate fire alarm circuit.



48501 shown

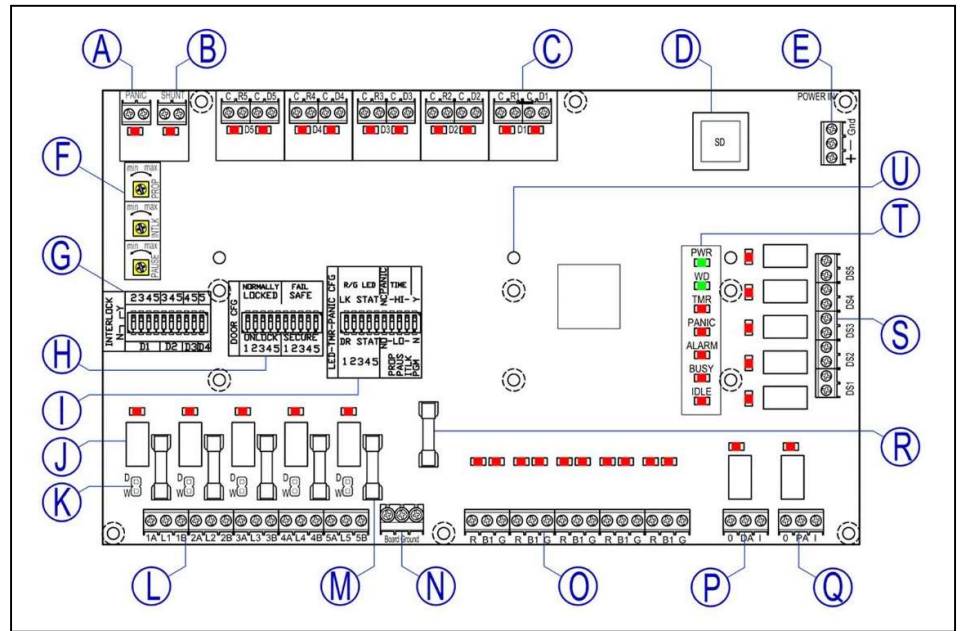

FIG. 1

- |                                  |                                 |                                   |
|----------------------------------|---------------------------------|-----------------------------------|
| A Emergency Unlock Input         | H Door Configuration Switches   | O Red-Green Traffic Light Outputs |
| B Interlock Shunt Input          | I Output Configuration Switches | P Door Alarm Output               |
| C Door and Access Control Inputs | J Lock Control Relays           | Q Panic Alarm Output              |
| D SD Memory Card Slot            | K Lock Output Wet Dry Select    | R LED Output Fuse                 |
| E System Power Input             | L Lock Control Outputs          | S Door Status Out - Dry           |
| F Timer Adjustment Controls      | M Lock Power Fuse 2 Amps        | T System Status Lights            |
| G Interlock Setting Switch Block | N Lock Ground Return Terminals  | U DIN Clip Release Openings (3)   |

## OVERVIEW

The 48500 controller allows for any combination of up to five doors to be interlocked by setting the appropriate switches.

The user may set doors for normally unlocked, locking only when an interlocked door is in use, or normally locked operation, requiring an access control signal to unlock when interlocked doors are secure.

There are five lock control relays that can power locks directly (wet contact) or operate as dry contact to switch power by others or for automatic doors.

The user may select fail secure (relay energizes to unlock the door) or fail safe (relay energizes to lock the door) operation.

There are five dry contact outputs to mirror door status back to access control devices when needed.

Five powered outputs are provided to illuminate door or lock status red and green LEDs. Locked doors can be set for either lock status (red when locked, green when unlocked) or door availability (green when locked but available and red when locked but not available because an interlocked door is in use). Lights for unlocked doors always indicate lock status.

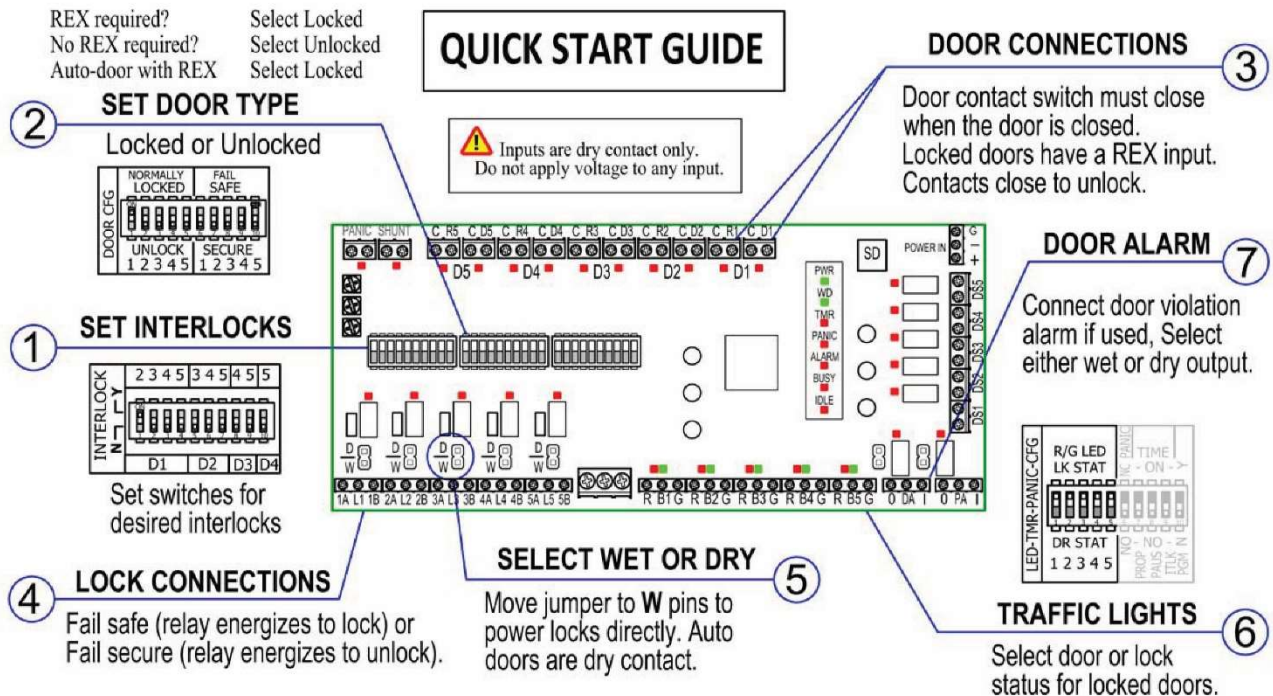
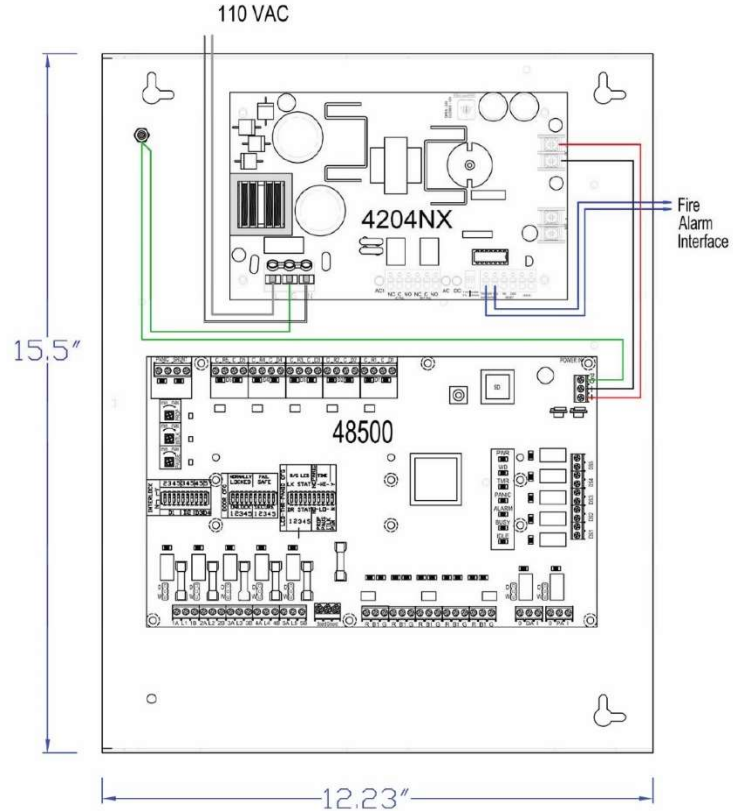

## HOOKUP and MOUNTING

### DIN RAIL OR STANDOFFS (U)

The DIN rail clips may be used to mount to standard DIN rail track, or standoffs may be used. The DIN rail allows the installer to make most of the wire connections with the controller free of the enclosure. When connections are complete, the controller snaps onto the track. Use a small screw driver to unclip the controller. Insert driver through DIN clip release opening (U). Engage the slot, press down and away to release the clip. Repeat for each clip.

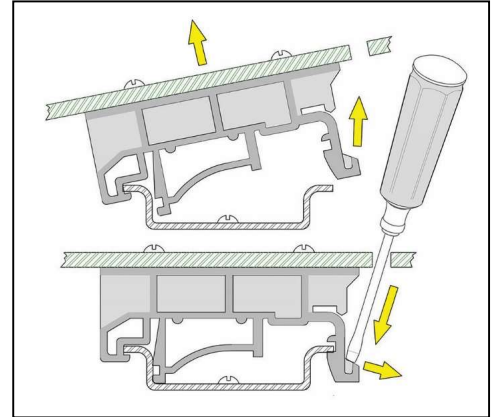

### DOOR POSITION SWITCH (C)

**Door switch contacts must be closed when the door is closed** – the red door input LED lights to indicate closed contacts. Twisted pair wiring – AWG gauge 22 or larger is recommended for all signal inputs.

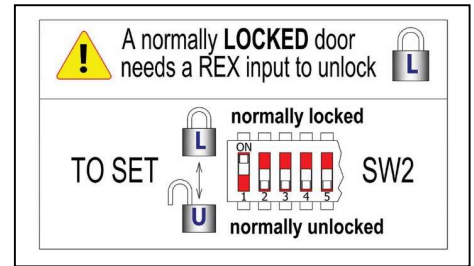
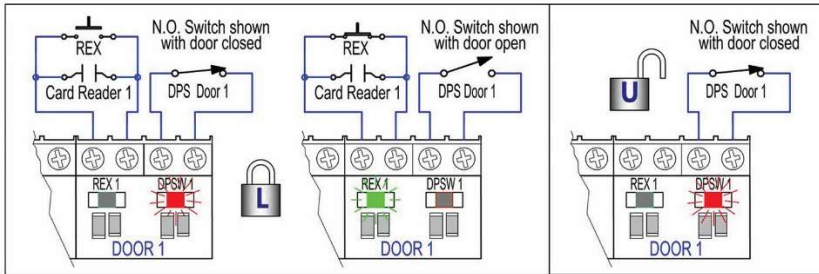

### ACCESS CONTROL INPUT (C)

Connect access control output to 4800 REX input. The request for access can be from a card reader, biometric reader, motion detector, pushbutton or any similar device. The lock relay follows the REX input unless the unlock timer is enabled (see timer section for Unlock Pause below). The unlock timer allows the user to determine the unlock period after a valid REX.

Inputs are dry contact only. Use an isolation relay for non-dry contact connections (such as a powered output from an intercom). AWG gauge 22 twisted pair or larger is recommended. Use sufficient wire diameter to minimize voltage drop for long wire runs. Use shielded wire in proximity to sources of interference such as large motors, network servers, and sources of electromagnetic radiation.

Each door can be set for normally locked or normally unlocked operation using SW2 switches (see below), however if a door is set as normally locked, it must have closed contacts at the REX input to unlock.

### LOCK OUTPUT (L)

Lock power is switched by the lock relay. The user selects the operation of the lock output, either Fail Safe (lock relay energizes to lock the door) or Fail Secure (lock relay energizes to unlock the door). User also selects whether the lock power is supplied by the controller (wet contacts) or by some other source (dry contacts).

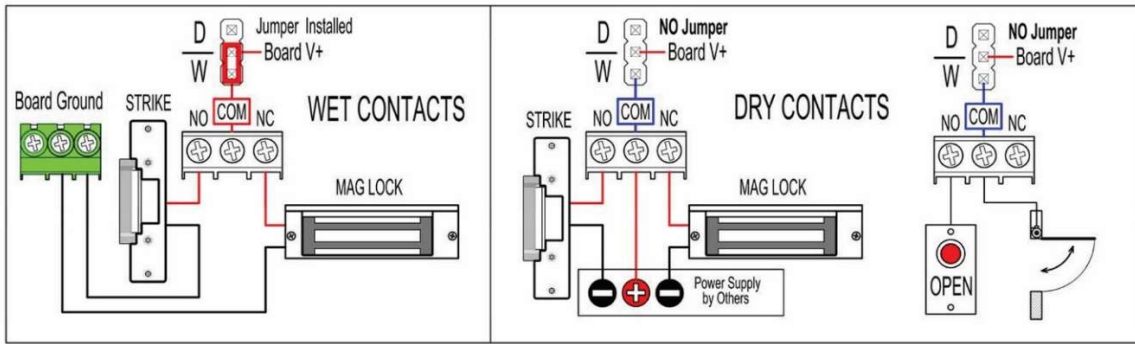

**DOOR LOCKS**

Mag locks and strikes are connected to the designated relay contacts by labeled screw terminals. Relay outputs are either dry or wet contacts. With the jumper in the W position, relay common is connected to V+. Lock power is switched directly by the 4800. Remove the jumper for dry contacts. When relays are operated with wet contacts shorting the output **will blow the fuse and may damage the controller!** Lock outputs are individually fused.

**NOTE:** Use a wire of sufficient diameter and rating to minimize voltage drop, especially over long wire runs. AWG 18 or 16 gauge is recommended for power circuits. Max current through the relay contacts is **2 Amps**. For high current applications such as motorized draw bolts, an external high current relay or contactor must be used,

**AUTOMATIC DOORS**

Automatic doors, rollups, swing or overhead can be operated as unlocked or locked. In unlocked operation, the relay contacts are used to interrupt the open command circuit when an interlocked door is open.

For **locked operation**, the open request is connected to the REX input and the door control relay follows the open request **unless an interlocked door is in use**. When operating automatic doors in the locked door mode, set the Pause timer switch to GO (see Set Timer Functions below) and adjust the Pause rotary control for a delay of 1 or 2 seconds to allow the auto door time to move enough to open the door position sensor contacts before the request signal expires to prevent possible simultaneous open commands being passed to the auto door actuators.

Dry **contact** outputs (no jumper) **must be used for automatic doors**.

**TRAFFIC LIGHTS (O)**

The fused Traffic Light outputs for all doors are powered for direct connection to LEDs. Do not short any powered output. A single fuse protects the traffic light array from overcurrent and short circuits.

Traffic lights for unlocked doors indicate lock status showing green when the door is unlocked and red when the door is locked.

Traffic lights for locked doors, indicate door availability status showing green when the door is locked but available for use and red when the door is locked but not available because an interlocked door is in use. The user selects either lock status or door status by adjusting the configuration switches for each door. Note: regardless of the settings, a normally unlocked door will only show lock status.

AWG 22 gauge or larger is recommended for signaling and low-power indicator circuits.

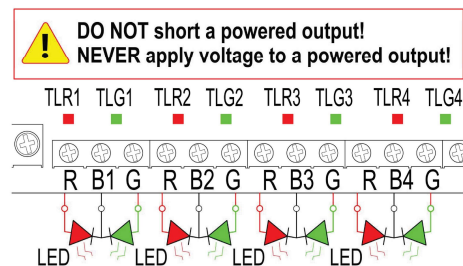
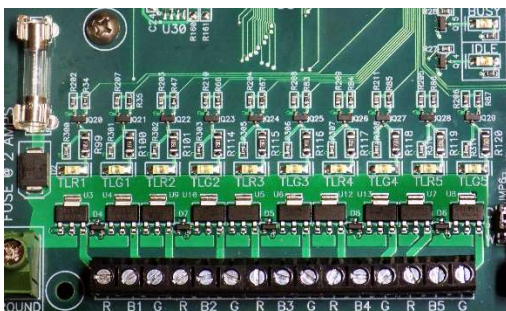
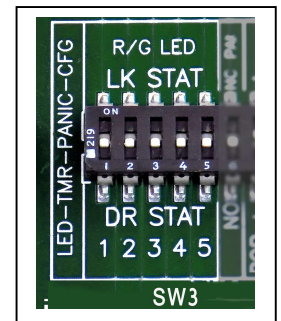

**DOOR ALARM (P)**

A non-fused relay output is provided for a Door Alarm output. The relay is energized if a locked door is open without a valid REX (forced door), if two interlocked doors are open at the same time or when the door propped timer is enabled, if the door is open past the user selected time limit. Alarm relay outputs may be used wet or dry. Use wet output to operate an alarm sounder or light. Wet contacts are enabled by moving the jumper to “W”. Do not exceed contact rating of 2 Amps. The door alarm is disabled when the Shunt input is active (closed contacts across input).

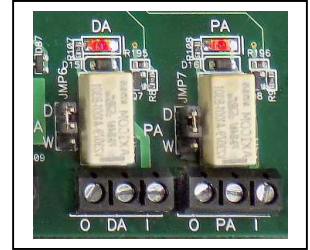

**PANIC ALARM (Q)**

A non-fused relay output is provided for a Panic Alarm output. The relay is energized if the doors are unlocked via an active Panic Input. Select wet or dry contacts. 2 Amps max.

**EMERGENCY UNLOCK (A)**

The Panic release unlocks all doors regardless of door status for immediate egress in an emergency.

Use a maintained contact switch at the terminals shown on the drawing for the system being installed. When actuated, the doors will unlock for as long as the switch contacts remain closed. For a timed panic unlock, see the section on timers below.

**Note:** Panic unlock input can be selected for normally open or normally closed activation. See below.

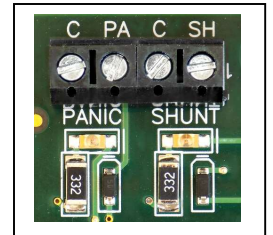

**DOOR STATUS OUTPUTS (S)**

Door Status is provided for connection to Access Control devices or any system that monitors door status. These outputs follow the DPS inputs and are dry contact only. LEDs show when relay is energized (door is closed). Outputs follow DPS inputs for each door.

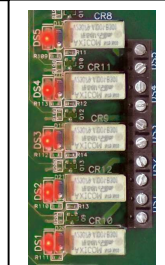

**INPUT STATUS INDICATORS (C)**

When an input is grounded (closed dry contacts) the input is active. This is indicated by a lighted LED. The inputs for the 4800 programmable controller are opto-isolated for protection against most kinds of interference.

Door Position Switches, Magnetic Bond Sensors and similar devices used to signal door status, use the Normally Open contacts so that **when the door is closed the contacts are closed.**

When a door is closed the red input LED for the door will be lighted. This makes it easy to verify interlock operation and to troubleshoot a new installation. When the door opens, the LED should turn off.

For other REX devices such as Bio-sensors, card readers, motion detectors, pushbuttons, pneumatic switches and the like, the green input LED should be on when the REX is active.

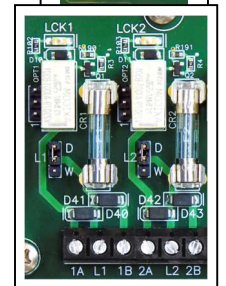

**LOCK OUTPUT FUSES (M)**

Lock power relay contacts are fused. If a fuse blows, determine the cause of the overcurrent condition and correct it before replacing the fuse. Use the correct quick blow fuse rated at 2 Amps.

**LOCK RELAY STATUS INDICATOR LED (J)**

LEDs indicate that an output relay is energized. With the output set for **FAIL SECURE**, the relay energizes to unlock or enable the door. Set for **FAIL SAFE** the relay energizes to lock or disable the door. Make connections accordingly.

For verifying desired operation, compare lighted inputs to the lighted relay indicators.

**AUTO DOORS WITH LOCKS. – AUX RELAY OUTPUTS**

For doors that have locks and automatic openers, the auxiliary relay contacts must be used. To access the auxiliary contacts, an optional wire harness is required. Order part number 4800-AUX HARNESS. The harness connector is pressed onto the three pin header adjacent to the relay.

Use the appropriate relay contacts to interrupt the “OPEN” request, or to signal access control to inhibit the door mechanism. The lock is connected to the fused contacts and may be set for either wet or dry operation.

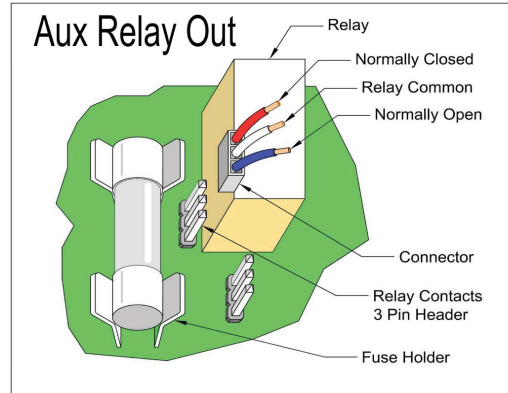

BASIC SETTINGS

**FACTORY DEFAULT SETTINGS – AS SHIPPED**

- Doors 1 and 2 are interlocked. Door inputs for 3, 4 and 5 are jumpered.
- Lock relays energize to unlock (Fail Secure)
- Doors are normally unlocked
- Status indicators show lock status (green for unlocked and red for locked)
- Timers are disabled.
- Panic Input is Normally Open – Panic contacts close to activate emergency unlock.

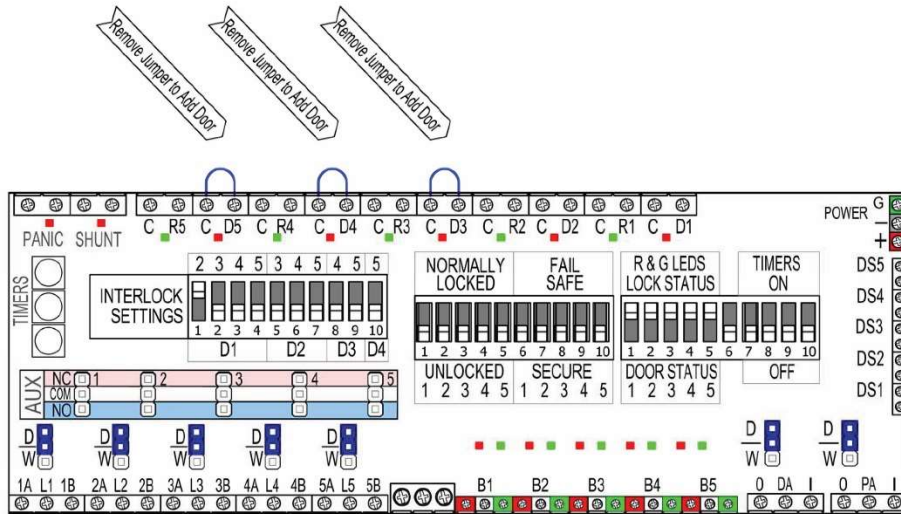

**STEP ONE – SET DOOR INTERLOCKS**

Set the door interlocks first. All interlocks must be reciprocal: if door 1 is interlocked with door 2 then door 2 is automatically interlocked with door 1. Only one switch is used to interlock both doors. Switches are arranged in blocks by door number. D1 = Door 1, D2 = Door 2 and so on. Above the D1 block are 4 choices, doors 2, 3, 4 and 5. Note that each block has one less choice than the previous block to prevent duplication. D2 block does not include a choice for door 1 because that is set in the D1 block of switches.

1. Select all doors that interlock with door 1 and move the switch for each door to the Y (on) position.
2. Select all doors that interlock with door 2. Remember: if door 1 and door 2 are interlocked, that selection is made in the door 1 block of switches.
3. Select the rest of the interlocks in a similar manner.
4. If no selection is made, that door will not be interlocked. The controller will ignore the status (open or closed) of any door not selected to be interlocked with another door or doors.

<p><b>EXAMPLE:</b> illustrated right with 4 doors. Door 1 interlocks with door 2. Door 3 interlocks with door 4. Door 5 is not interlocked and is ignored.</p> <p>If door 1 opens, door 2 locks. If door 3 opens, door 4 locks.</p> <p>Only 2 switches are needed for the interlock.</p>		
--	--	--



**STEP TWO – SET LOCKED OR UNLOCKED OPERATION**

Each door must be configured for normally locked or unlocked operation. If an access control input of any kind is required to open the door, the door is considered normally locked. This is true for automated doors of any kind, swing doors, rollup doors, sliders and overhead doors even if they have no locks, but an input is required in order to gain access. An access control input can be any dry (no voltage) contact closure from a card reader, scanner, pushbutton, motion detector, or remote guard console. The access control input is also called a REX input.

If the door does not need an access control input to open, it then is unlocked unless an interlocked door is in use. If a door is selected to be normally unlocked (the factory default) the REX input for that door is ignored.

**EXAMPLE:** In the example at the right, Door 1 is locked. All of the other doors are normally unlocked. All lock outputs are **FAIL SECURE** meaning that the relay energizes to unlock the door.

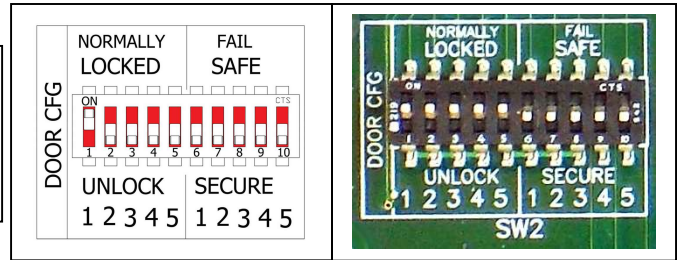

**STEP THREE – SET LOCK RELAY FOR FAIL SAFE OR FAIL SECURE**

The factory default is for Fail Secure lock relay operation. This means that the relay energizes to unlock the door. Typically, mag locks are connected to the normally closed relay contacts and strikes bolts are connected to the normally open contacts. For other lock types connections may vary. Check manufacturer’s recommendations.

If **FAIL SAFE** operation is required, move the switch for each door to the in the Door Configuration switch block to the Fail Safe position (on). See illustration above.

**STEP FOUR – SET WET OR DRY LOCK OUTPUTS**

Lock outputs can be either wet (supply positive voltage at the output) or dry (no voltage at the output). To use the DORTRONICS power supply to directly power the door locks, select wet operation by installing a jumper. To have the relay switch lock power from another source, remove the jumper. **With jumper removed or in the dry (D) position, the output is dry.**

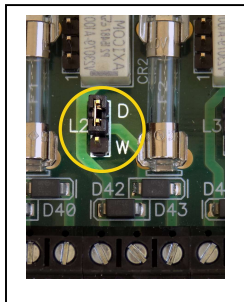

**! DO NOT short a powered output!  
NEVER apply voltage to a powered output!**



## OPTIONAL FUNCTION SETTINGS

### SET WET OR DRY ALARM OUTPUTS

There are two alarm out relays. They can be used to power sounders, strobes, or other powered indicators directly by installing the wet output jumper. For dry output to signal other monitoring stations remove the jumper.

The **Panic Alarm** relay is energized when the Emergency Unlock input is active or the unlock timer is running.

The **Door Alarm** relay is energized if a locked door is open without a valid REX (forced door) if two or more interlocked doors are open at the same time, or if a door is propped open when the door prop alarm timer is set. The **forced door alarm** may be disabled or enabled by moving the PGM switch to “Y” or “N”. Set to N for doors with card reader in and mechanical release such as a crash bar or lever unlock.

### SET TIMER FUNCTIONS

There are three onboard timer functions: Door Propped Timer; Unlock Pause Timer; Interlock Timer. Each timer is enabled by moving the appropriate switch to **GO** and disabled when the switch is set to **NO**.

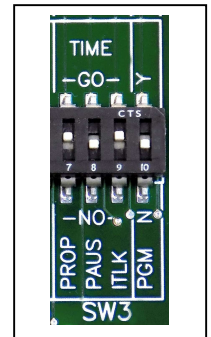

### PROPPED DOOR TIMER

The **Door Propped** timer, when enabled, begins timing as soon as any door is open. If the door is open when the timer expires, the door alarm output relay energizes. Use the rotary control to set the time delay to any value between 14 seconds and 7 minutes.

### EMERGENCY UNLOCK TIMER

The **Interlock** timer, when enabled, begins timing when the Emergency Unlock input is activated. All doors remain unlocked and automatic doors remain enabled until the timer expires. Set to any value between 2 and 120 seconds. Emergency unlock overrides System Pause and unlocks all doors. Door/lock lights go green.

### UNLOCK PAUSE TIMER

This is typically used when a momentary REX device is located some distance from the door. The timer allows the user time to get to the door and open it after making the request for access. The **Pause** timer, when enabled, determines the time a locked door remains unlocked after a valid request by access control, a pushbutton, motion detector or similar device. This only applies to doors that are set as normally locked. Use the rotary control to adjust the unlock time between 1 and 30 seconds.

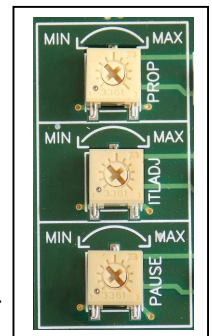

### SET DOOR INDICATION LIGHTS

Door light outputs are available to let the user know when a door may be opened. Normally unlocked doors use lock status indicators where green indicates the door is unlocked and red indicates that the door is locked.

Normally locked doors use either lock status or door status where green indicates that the door is ready to be unlocked and red indicates that the door is not ready to be unlocked because another door is in use.

Either lock status or door status can be selected for each door by setting the R/G DIP setting.

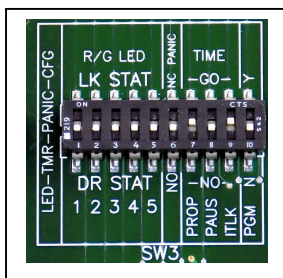

As shown at right, the door indicator lights can be set for either lock status or door status. In the example shown, door 1 is normally locked and the door lights indicate door status. Doors 2, 3, 4 and 5 are normally unlocked and the door lights indicate lock status - locked or unlocked.

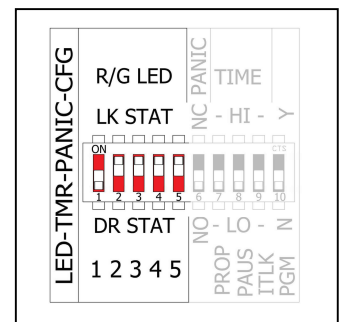

**SET EMERGENCY UNLOCK INPUT FOR NORMALLY OPEN OR NORMALLY CLOSED**

The emergency unlock feature (Panic) allows for all doors to be unlocked regardless of interlock status for as long as the input is true. The input can be set to unlock all doors on either a make (N.O.) or break (N.C.) of the emergency unlock circuit. If pull boxes or any similar series connected switches are used, the Panic input should be set to normally closed (N.C.). If pushbuttons, or alarm circuits with parallel connections are used, Panic should be set to normally open (N.O.) as shown above.

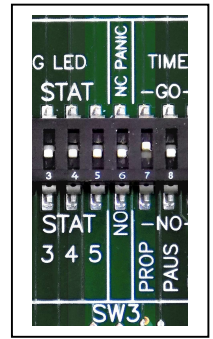

**OTHER FEATURES**

**INTERLOCK BYPASS - SHUNT**

The 4800 controller allows for the interlock logic to be bypassed when desired. This feature is typically used to allow unrestricted access at certain times of the day, or to allow for maintenance or cleaning service to open more than one door at a time for the movement of materials, or equipment.

Connect a normally open maintained contact switch (typically a keyed switch, but a card reader, keypad or other secure input device could be used) to the SHUNT input. The interlock function is disabled for as long as the shunt switch contacts are closed. Any normally locked doors remain locked and must be opened by means of the normal access control sequence, however multiple doors normally interlocked may be open at the same time.

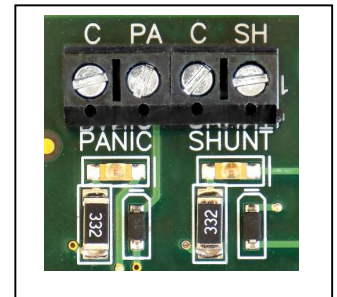

Door alarms for forced door, interlock violation and propped open are disabled when interlock is shunted.

**SYSTEM STATUS LIGHTS (L)**

**POWER (PWR)**

The power status light glows green whenever the 4800 is connected to 12-24 VDC.

**WATCHDOG LED (WD)**

The PLC is continually monitored by a watchdog function. The watchdog LED blinks rapidly (at a rate of 3 times per second) to indicate that a program is loaded and is being executed correctly.

**TIMER LED (TMR)**

The timer light indicates that one of the three timers is running. If the Panic light is also lit, the emergency unlock timer is running. It is important to check the timer light if the system is not responding to other inputs. The System Pause timer and the Panic timer while running will ignore requests for access. If a timer has been set inadvertently, make sure the timer “GO – NO” switches in SW3 are set to “NO”

**PANIC**

A lit Panic LED indicates the Panic input or the emergency unlock timer is active. All doors remain unlocked until the timer expires or the input is reset.

**ALARM**

A lit Alarm LED indicates either a door alarm or an emergency unlock alarm.

**BUSY**

The Busy LED is lit when the system is not idle: a door is in use; a timer is running; or there is an alarm condition.

**IDLE**

Idle light indicates that the system is monitoring all doors and requests for access. None are active. No alarms are active. No timers are running.

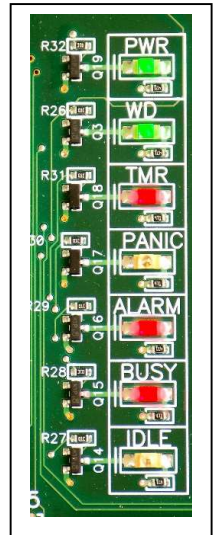

## TROUBLE SHOOTING THE INSTALLATION

Visual indication of all inputs, outputs and system status is provided for verification of all conditions and settings. If the installation does not operate as desired, check the following in the sequence shown:

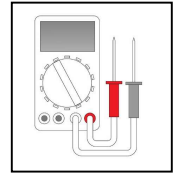

### NOTHING WORKS

1. **POWER LIGHT** - The controller requires 12 – 24 VDC to operate. Verify the green POWER LED is lit. If not:
  - a. Check the power supply connections
  - b. Check the power supply output terminals
  - c. Check the Power Supply fuse
  - d. Check the Mains connection and the fuse at the 110 VAC terminal.
2. **WATCHDOG LIGHT** - If power connections are correct and the POWER LED is lit, verify that the Watchdog LED is blinking at a constant rate of 3 blinks per second. If it is not blinking, call Dortronics Technical Assistance.
3. **DOOR INPUT LIGHTS** - Verify that each door that is to be interlocked by the controller is closed and that the input LED for each interlocked door is lighted. Unused door inputs can be jumped out if needed.

If it is not possible to keep the doors closed while troubleshooting because the facility is in use, temporarily jump the door inputs for all interlocked doors. Use a short piece of wire as a jumper. Jumper unused door inputs as well.

4. **REX INPUT LIGHTS – For Locked Doors Only:**
  - a. Verify that no REX inputs are active and that no rex input lights are lit.
  - b. Make sure door is correctly configured. Verify that the door configuration switch is correctly set to “LOCKED” position for the door being tested. If it is set to unlocked, the REX input is ignored.
  - c. To test a REX input, use a short piece of wire to jump the two REX input terminals. Verify that when a designated REX input is active, the corresponding lock relay changes state (shown by the relay LED for the lock relay being tested). Door 1 REX operates Door 1 lock and so on.
5. **LOCK RELAY “ON” LIGHTS**
  - a. When the system is **IDLE** and the idle light is on, verify that all normally unlocked fail secure doors show a lighted (energized) relay.
  - b. Are the relays on when they are supposed to be?
  - c. Verify that all normally locked fail secure relays are not energized (relay LED is off).
  - d. For Fail Safe settings, the relays should be ON when locked and off when unlocked at idle.
6. If the relays do not reflect the desired state check:
  - a. The door configuration is correct for the desired operation.
  - b. The door position inputs for all doors in the interlock are closed – the input LED is on.
  - c. That no REX inputs are active – REX LEDs are all off.



Make sure the doors are correctly set for the desired operation. For a normally locked door set switch corresponding to the door to the “on” or up position. For Fail Safe lock operation, set the switch corresponding to the door in the up or “ON” position.

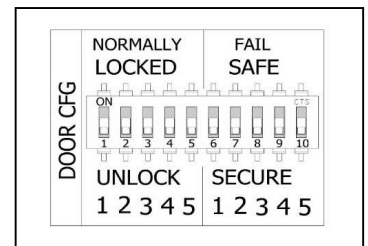

**NO LOCK POWER**

1. Check the lock relay fuse.
2. If the controller supplies power to the locks check that the jumper is on the **W** position. Use a multi-meter to verify that lock relay common is at the supply voltage.
3. Check that the lock is connected to the correct output. For Fail Secure operation the mag lock connects to N.C. contacts. Strikes connect to N.O. contacts.

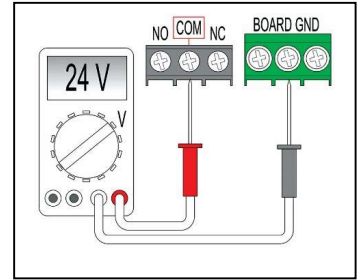

**STAYS IN DOOR ALARM**

1. Check that all interlocked doors are closed - door inputs are “ON”. If there is any doubt that a door position switch is operating correctly, use a piece of wire to jumper the input. Remember: DPS inputs show red and REX inputs show green input LEDs.
2. Check that the Panic (emergency unlock timer) is not set and running. System Idle light should be lit.

**DOOR LOCKS WHEN IT SHOULD UNLOCK**

1. Make sure the lock is connected to the correct contacts on the lock relay. Some locks can be set for either Fail Safe or Fail secure operation. Make sure the lock type matches the controller lock logic. The lock relay is energized when the door is unlocked when Fail Secure.
2. Check that the Fail Safe – Fail Secure setting is correct for the application.

**DOORS REMAIN UNLOCKED AT ALL TIMES**

1. Check Panic relay and System Status Panic light. If they are on, check that the Panic N.C. – N.O. switch (SW3) is set correctly. If the switch is set to N.C. and there is no Panic input, the doors will remain unlocked. If the switch is set to N.O. and the panic input is closed (light is lit) the doors will remain unlocked.

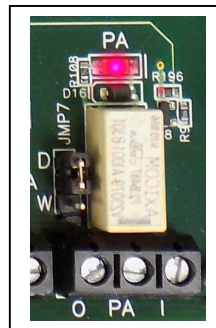
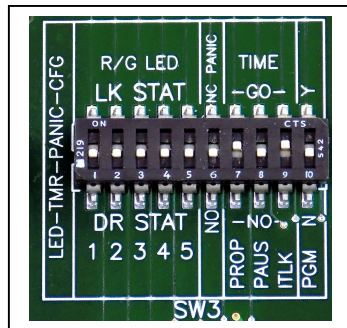
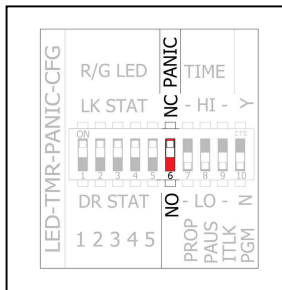

If Panic output is lit and there is no connection at the Panic input, the Panic input is set to N.C. – change setting to N.O.

SOME EXAMPLES

4 DOORS UNLOCKED

4 maglocks with powered outputs for fail secure operation. No timers selected. R/G lights show lock status. All doors interlocked. If any door opens the others lock. Doors normally unlocked

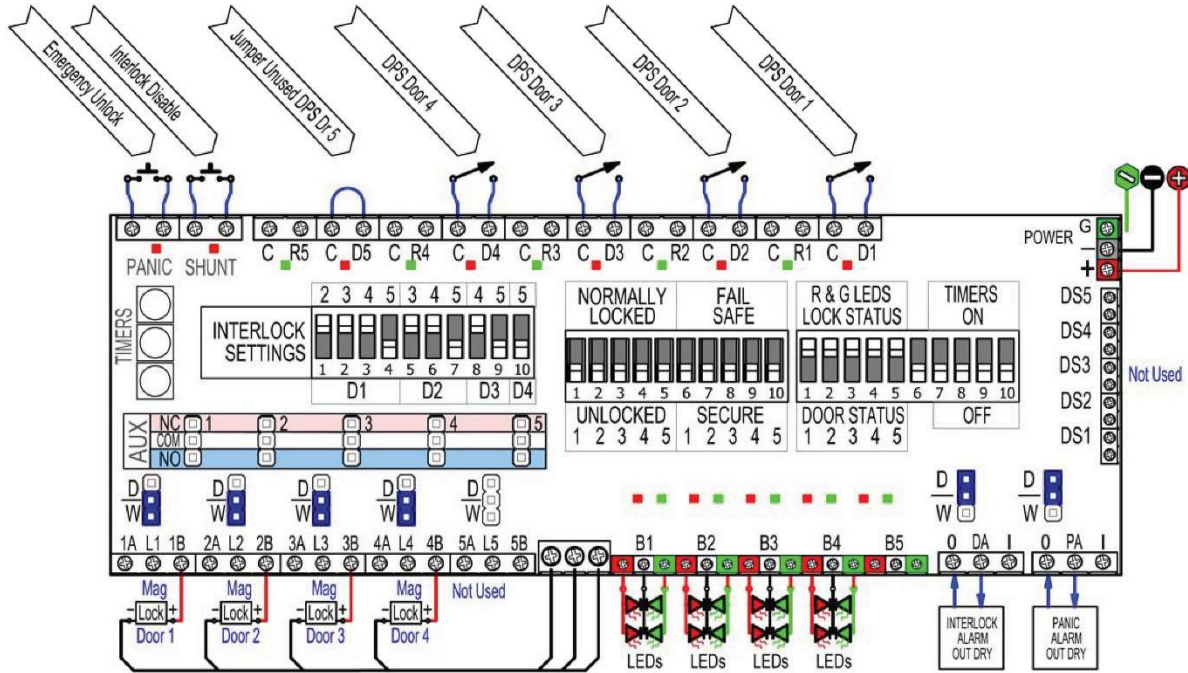

5 DOOR LOCKED

5 maglocks with powered outputs for fail secure operation. No timers selected. R/G lights show door status. All doors interlocked. If one opens others are inhibited. Doors normally locked. Door status output to access control.

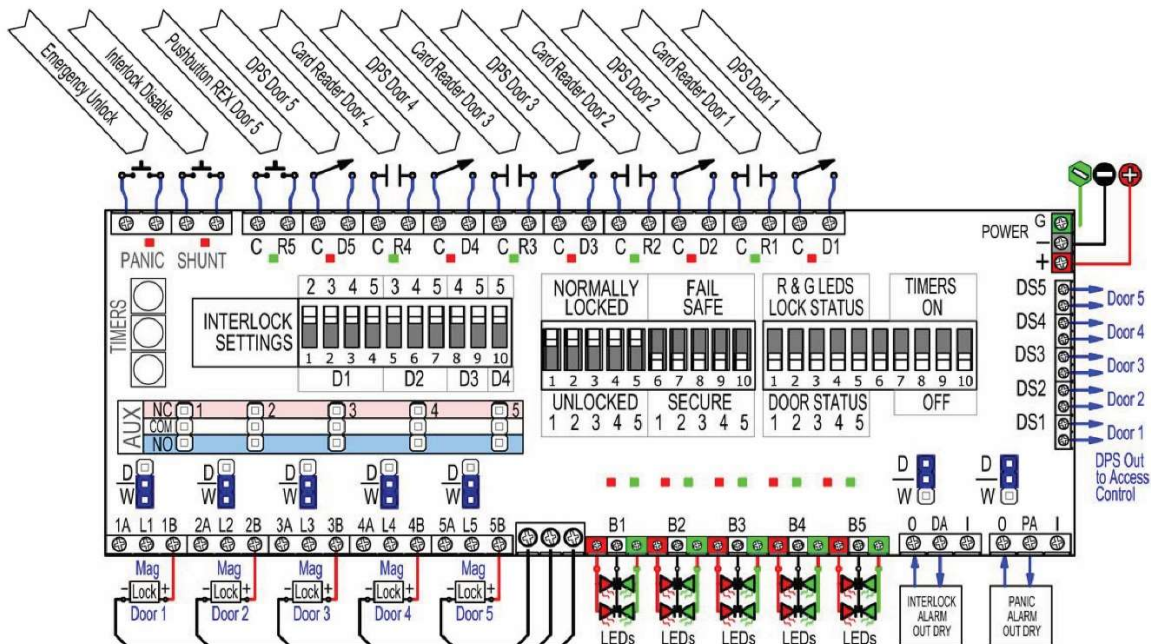

### 3 DOORS 1 LOCKED 1 SHARED

3 doors, 1 locked. Door 2 is shared. If 2 is open 1 and 3 are not available. If 2 is closed 1 and 3 can be used at the same time. Prop timer is set to alarm if any door is open beyond selected time limit.

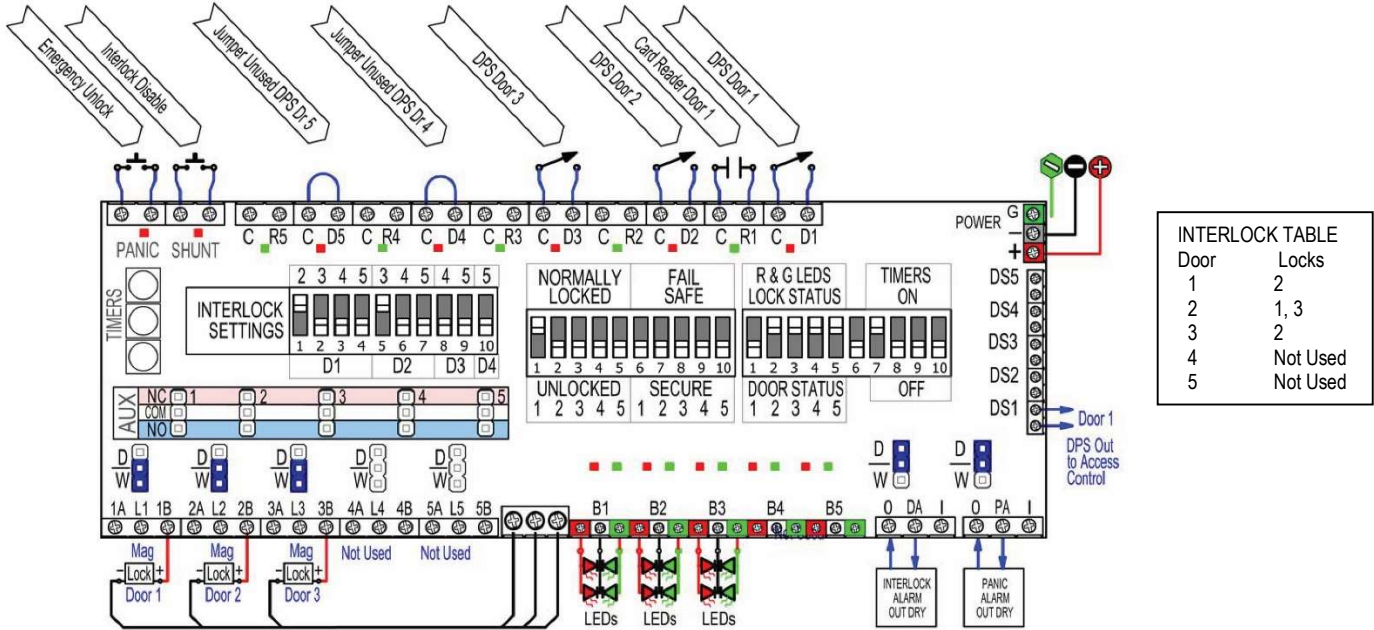

### 4 DOORS 2 MAN, 2 ROLLUP, 1 LOCKED

4 doors, 1 locked. Doors 1 and 2 are man doors with strikes. Doors 3 and 4 are rollups. If any door opens, others are not available. Rollup door UP command is interrupted by dry contact output. Door alarm is a sounder using wet contacts.

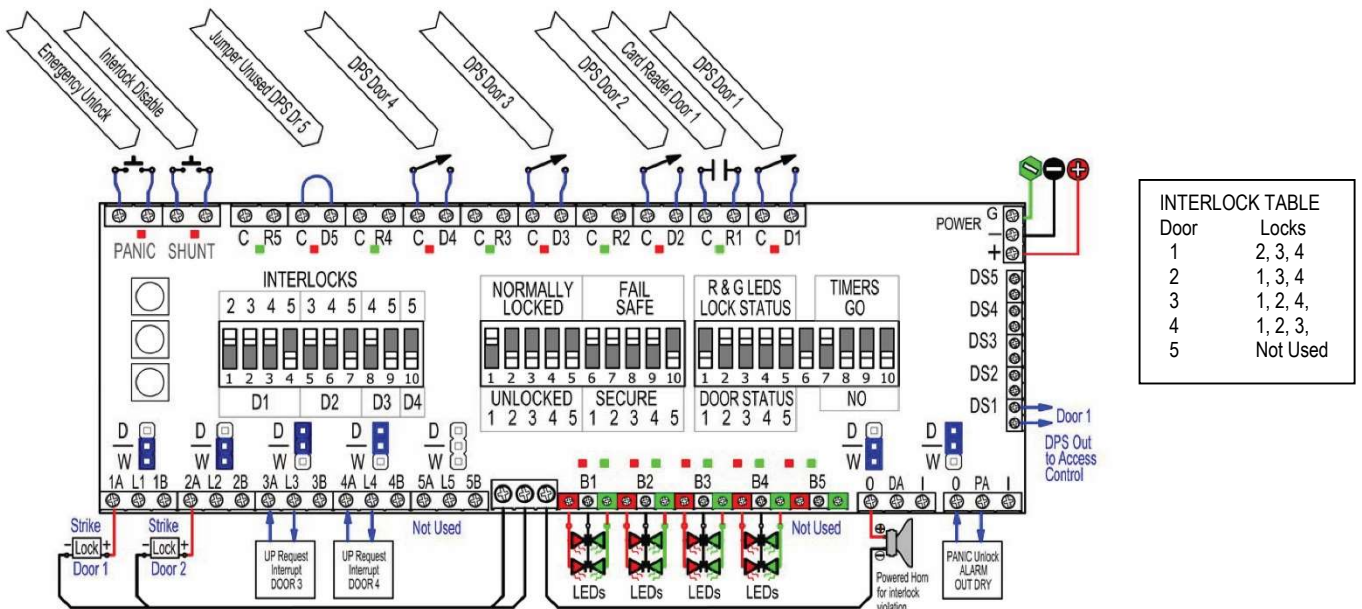

5 AUTOMATIC DOORS WITH MAG LOCKS

For doors with automatic openers and locks, an optional auxiliary output is required, part number 48500xAUX or 48501xAUX. The option allows the user to access a second set of contacts on each door control relay. As shown below, the primary contacts switch lock power and the secondary contacts mirror the REX input out to the auto-door opener. When an interlocked door is in use, the output does not change state.

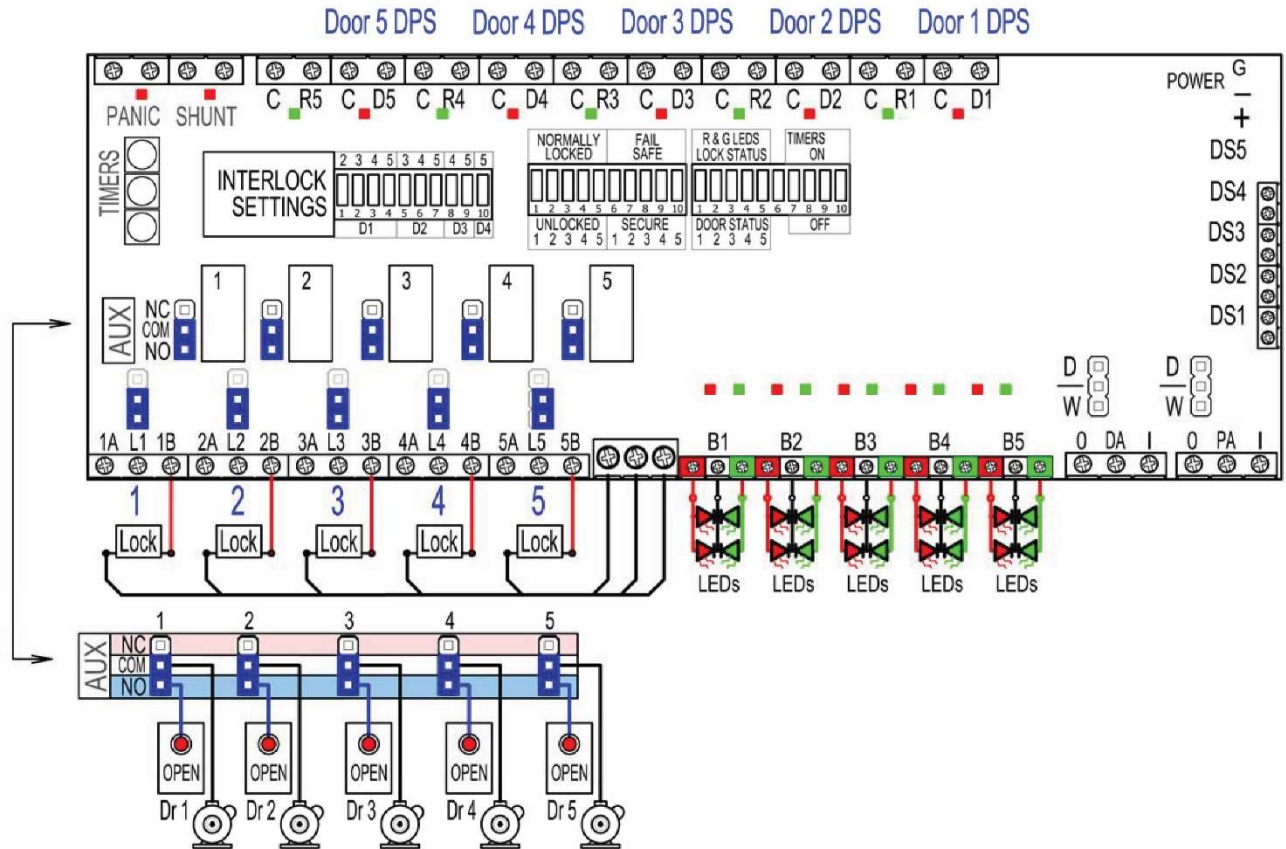

SAMPLE 4805 INTERLOCK SETTINGS

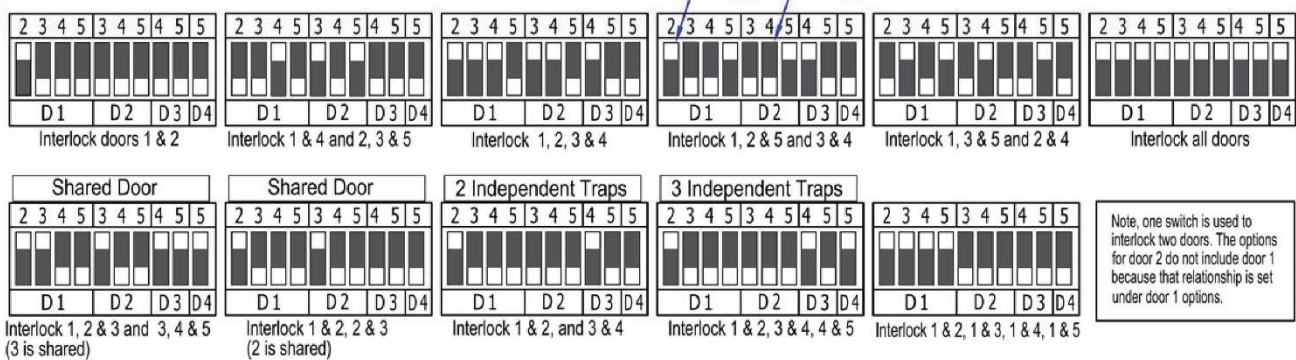

## POWER SUPPLY SPECIFICATIONS

The 4204NX power supply/charger converts a 120VAC 60Hz input into a single PTC protected Class 2 power-limited output. Output is selectable for 12VDC or 24VDC with a total of 4A max. It also offers a suite of features that includes fire alarm disconnect, overvoltage protection, and low power disconnect which prevents deep discharge of stand-by batteries.

<p><b>Input</b></p> <p>Voltage 120VAC, 60Hz, 3.5A max. Fusing 5A / 250V.</p> <p><b>Outputs</b></p> <p>Voltage 12VDC or 24VDC selectable. Current 4A continuous max. Protection Fused 2.5A / PTC 2A. Auxiliary Class 2 power-limited @ 1A (unswitched). Other Overvoltage protection. Filtered and regulated.</p> <p><b>Back-up Battery</b> <i>(not included)</i> Capacity 7AH / 12VDC (1 or 2 within enclosure). Type Sealed lead acid or gel type. Fuse Rating 5A @ 32VDC. Failover Upon AC loss, instantaneous.</p>	<p><b>Fire Alarm Disconnect</b></p> <p>Supervised Latching or non-latching. EOL 10K Resistor.</p> <p><b>Supervision</b></p> <p>AC Failure Form "C" contacts. Battery Form "C" contacts. Low DC Power Shutdown Shuts down DC output terminals if battery voltage drops below 71-73% for 12V units and 70-75% for 24V units to prevent deep battery discharge.</p> <p><b>Indicators (LED)</b></p> <p>Input 120VAC is present. DC Output Powered. Battery Discharged or not connected.</p>
---	---

## CONTROLLER SPECIFICATIONS

	Qty	Description	Remarks
<b>Power In</b>		<b>12 or 24VDC</b> regulated - plus, common and earth ground	3 - Screw Terminals
<b>Inputs</b>	12	5 DPS, 5 REX, 1 Panic and 1 Shunt	Screw Terminals
<b>Outputs</b>	15	5 Fused Lock Relays, 5 Door Status Out, 5 R/G Light Powered Outputs	Screw Terminals
<b>Timers</b>	3	Single Turn Rotary Adjusters to set Time Delay	
<b>Temperature</b>		Operating 0-60° C	
<b>Mounting</b>		DIN Rail Clip or Standoffs	
<b>Dimensions</b>		6"W x 10"L x 1 3/4" H – with DIN Clip installed. 1 1/4" H without	
<b>Fuses</b>	6	2 Amp @ 250 Volts – quick blow	

Current Draw - Condition	Current in mA	Volts
Controller only	70	12
with all relays on – all indicator lights lit	250	12
Controller only	50	24
with all relays on - all indicator lights lit	160	24



## RECOMMENDED EQUIPMENT

DORTRONICS PART#	DESCRIPTION
Dortronics #1110xDxB	1200 lb electromagnetic 12/24 VDC maglocks with built-in door position and bond sense switches.
Dortronics #7201xL2-H	High intensity Red / Green LEDs on single gang S/S wall plate.
Dortronics #7202xL2-HxCS	High intensity Red / Green LEDs with Piezo sounder on double gang S/S wall plate. (Optional for use with security breach alarm output.)
Dortronics #5216 MP23PP/RXE2	Panic mushroom switch latching push, pull.

## SALES - WARRANTIES

### Contact (Sales):

Mike Palermo – Sales/Customer Service S –

Sales/Applications Specialist Bryan Sanderford - National Sales Manager

Contact (Technical): Stuart Arthur

Joe Hanna – Engineer/Applications Specialist

Contact (Credit): Janice Wilson – Accounting; New Customer Accounts

### Product Warranties:

All electromagnetic locks have a **LIFETIME GUARANTEE** against defects in material and workmanship. Defective units will be replaced or repaired based upon incoming evaluation and inspection.

All other Dortronics components of the Electric Locking System shall be similarly warranted for a period of one year. Expressed warranties are conditionally based on the requirement that the items covered within the guarantee are used and maintained in accordance with the manufacturer's recommendations. The full warranty policy is accessible on our website. <https://dortronics.com/sales-policies-and-procedures/>

A Return Authorization Number must be obtained and accompany all returns within 14 days of issue. Unused items returned for credit must be complete and packed in original unit box and are subject to a 15% restocking fee. Any shipping or order discrepancies must be reported within 5 days of receipt.

[www.dortronics.com](http://www.dortronics.com)

